

**Positioner SRG5xx (SRG5XXEBA9802)****Index:**

<b>1</b>	<b>General</b>	<b>2</b>
<b>2</b>	<b>Operation and electrical connection</b>	<b>2</b>
<b>3</b>	<b>Connection model</b>	<b>3</b>
<b>4</b>	<b>Instructions for adjustment</b>	<b>3</b>
<b>5</b>	<b>Technical data</b>	<b>5</b>

**Note:****Notes contain important information.****Warning:****Warnings indicate special methods or handling procedures which, if not followed properly, may result in serious injury.**

## Positioner SRG5xx (SRG5XXEBA9802)

### 1 General

The SRG5xx positioner (symbol fig.1) facilitates the control of an electric actuator by means of a set point with voltage output 0(2)...10V. A potentiometer with a resistance value of 100Ω to 10kΩ is used as an actual value in the actuator. The position control of the actuator is carried out using the SRG5xx, i.e. the positioner ensures that the actual value and thus the position of the actuator follows the set point.

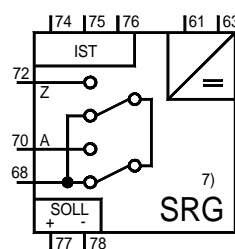

Fig.1: Symbol

### 2 Operation and electrical connection

The set point voltage  $U_1$  0(2)...10V is connected to the terminals 77 (plus) and 78 (minus). The actual value (actuator position) is determined in the SRG5xx from the position of the actual value potentiometer (connected to the terminals 74 to 76) coupled with the actuator. This actual value is compared with the set point in the positioner. If both values are equal except for a residual difference (adjustable with potentiometer D), none of the two relays (K3, K4) on the positioner picks up (see fig. 2).

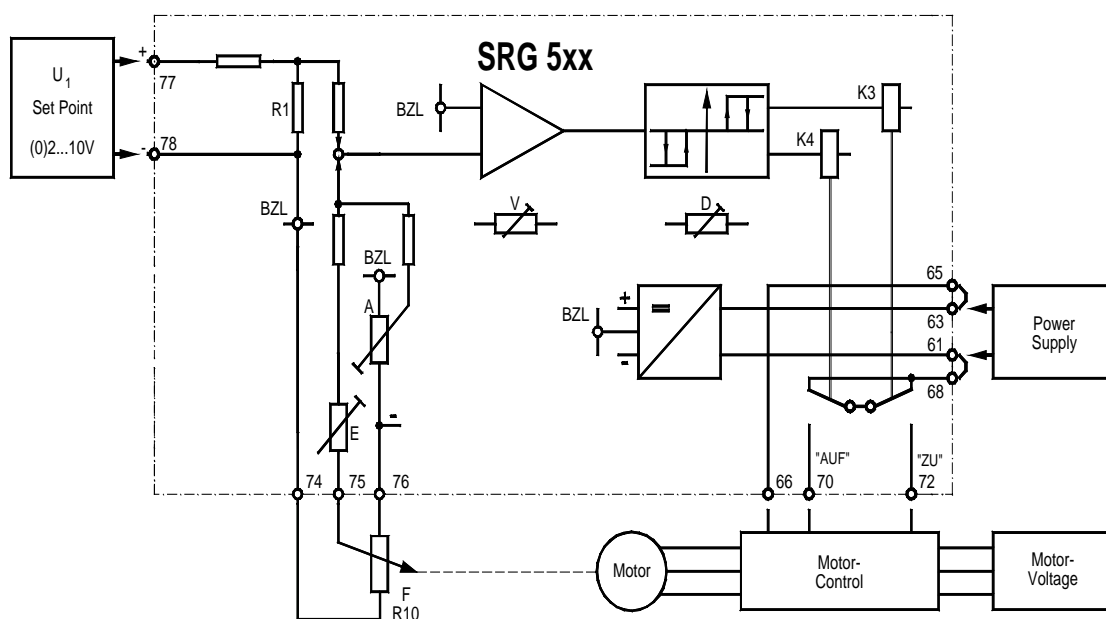

Fig.2: Basic circuit diagram

If the set point is larger than the actual value, the K4 relay picks up (the corresponding yellow LED lights), the actuator must open. If the actual value is larger than the set point, the K3 relay picks up (the corresponding yellow LED lights), the actuator must close. The control of the motor may be carried out directly via the relays of the SRG or via an additional reversing starter unit depending on the motor type.

The reference voltage required for control and the BZL reference line are separated galvanically from the supply. Thus, various positioners can be connected in series to the same set point (synchronization control, split-range control).

# Positioner SRG5xx (SRG5XXEBA9802)

## 3 Connection model

The positioner can be supplied in sub-unit terminal screw block (fig. 3) or in insert card block (fig. 4) version. The connection model is determined by the third digit of the designation (SRG5x1 for insert card block (fig. 4) and SRG5x2 for sub-unit terminal screws (fig. 3)).

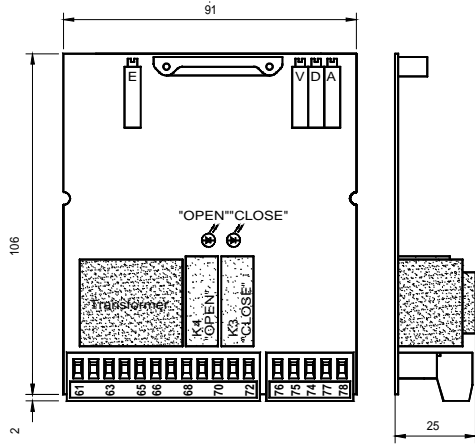

Fig. 3: SRG5x2

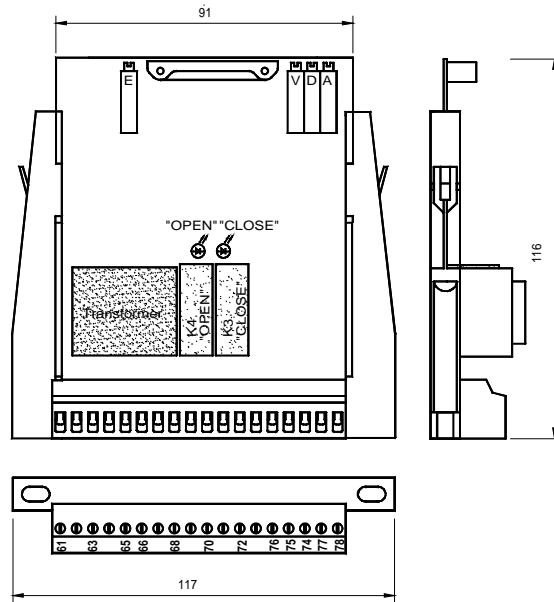

Fig.4: SRG5x1

## 4 Instructions for adjustment

### Switching difference D:

The switching difference (fig. 5) is adjusted using potentiometer D (figs. 3,4). If a more exact positioning of the actuator is desired, the the switching difference must be reduced. If the switching difference is too small, the actuator will start to oscillate. In case of actuator oscillation, the switching difference must be increased. This is achieved by turning potentiometer D in counter-clockwise direction.

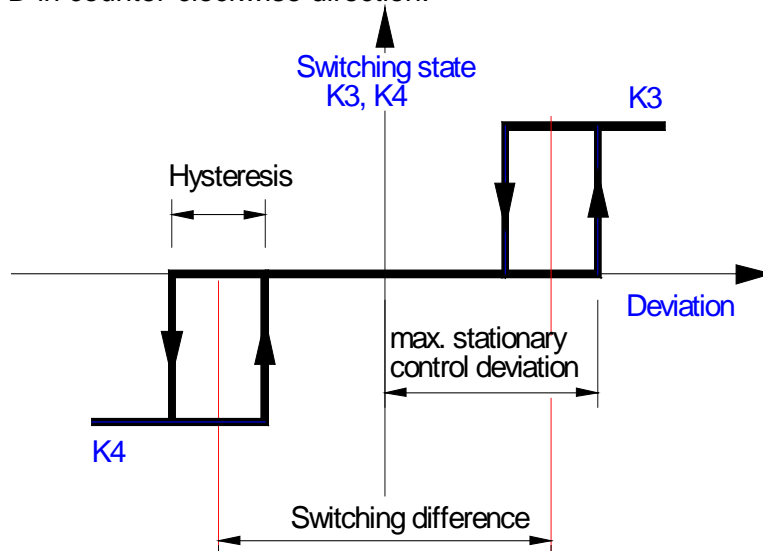

Fig.5: Switchpoints of 3-point controller

## Positioner SRG5xx (SRG5XXEBA9802)

### Filter V:

The filter type used is a phase-zero filter. This filter limits the increase speed of the control deviation. The effect of disturbances (high increase speed) is reduced effectively without impairing the control behaviour.

**ATTENTION!** A too large filter effect will cause the actuator to oscillate.

The filter effect is reduced by turning potentiometer V in clockwise direction.

### Adjustment procedure:

Adjust actuator according to operating instructions for the actuator. Set filter effect to minimum position by turning potentiometer V in a clockwise direction.

**Initial value:** Feed 0V (terminals 77 (plus) and 78 (minus)) at voltage input. The actuator moves into final position "CLOSED" and is switched off via microswitches S1 (torque depending closing) or S3 (travel depending closing). Turn potentiometer A on SRG in clockwise direction until relay K3 is released (can be seen on light emitting diode).

**Final value with set point 0...10V:** Feed 10V (terminal 77 (plus) and terminal 78 (minus) at voltage input. The actuator moves in direction "OPEN" and the travel switch S4 (travel depending opening) and torque switch S2 (torque depending opening) should switch. If S4 or S2 have not already switched, turn potentiometer E in clockwise direction until S4 or S2 responds and relay K4 remains picked up. Then turn potentiometer E slowly in counter-clockwise direction until relay K4 is released and K3 does not pick up yet.

**Final value at set point 2...10V:** Feed 8V (terminal 77 (plus) and terminal 78 (minus) at set point input. The actuator moves in direction "OPEN" and the travel switch S4 (travel depending opening) and torque switch S2 (torque depending opening) should switch. If S4 or S2 have not already switched, turn potentiometer E in clockwise direction until S4 or S2 responds and relay K4 is released. Increase set point to 10V, K4 picks up. Turn potentiometer A in counter-clockwise direction until relay K4 is released and K3 does not pick up yet.

### Control and correction of adjustment:

**Initial value:** Feed minimum set point (0 or 2V). The actuator moves into final position "CLOSED". If S3 or S1 switches and K3 remains picked up, turn potentiometer A in clockwise direction until K3 is released and K4 does not pick up yet. If K3 is released and S3 or S1 has not switched yet, turn potentiometer A in counter-clockwise direction until S3 or S1 switches. If K3 remains picked up, turn potentiometer A in clockwise direction until K3 is released and K4 does not pick up yet.

**Final value:** Feed set point 10V. The actuator moves into final position "OPEN". If S4 or S2 switches and K4 remains picked up, turn potentiometer E in counter-clockwise direction until K4 is released and K3 does not pick up yet. If K4 is released and S3 or S1 has not switched yet, turn potentiometer E in clockwise direction until S3 or S1 switches. If K4 remains picked up, turn potentiometer E in counter-clockwise direction until K4 is released and K3 does not pick up yet.

Finally, determine the optimum adjustment of the switching difference with set point steps. When turning potentiometer D in a counter-clockwise direction, the switching difference is increased. The set point steps should be in the opposite direction

## Positioner SRG5xx (SRG5XXEBA9802)

(reverse clearance) and their magnitude selected so that the actuator is able to reach its set point speed.

Then the filter effect can be increased to the desired stability reserve again by turning potentiometer V in a counter-clockwise direction.

### 5 Technical data

Supply voltage SRG51X .....	220V AC, +10%/-15%, 47...63Hz
SRG52X .....	20...30V DC, smoothed; (+...63, -...61)
SRG53X .....	110V AC, +10%/-15%, 47...63Hz
Power consumption .....	approx. 1.5 VA
Ambient temperature .....	-20...+60°C
Set point signal .....	0(2)...10 V
Actual value potentiometer .....	100Ω...10kΩ
Switching threshold of the control .....	max. 2.8mA
Switching difference .....	0,5...5% of final value
Hysteresis .....	approx. 25% of switching difference
Relay: Switching capacity .....	4A, 250V AC1
Mechanical life .....	20 mill. cycles

Electromagnetic compatibility:

The function of the SRG can be influenced by heavy electro-magnetic disturbances. After interference decay, the original function is restored and new alignment is not necessary. We advise to use shielded cables for the signal lines of the SRG.